

Our associates will ensure the tool works properly before you leave the store. If you experience issues with the tool while completing your project, simply bring it back to the Tool Rental Center to get a replacement. If you purchase Damage Protection at the time of your rental, you are not responsible for repair costs for tools that break due to normal use.



Owner's Manual

MMTC35HA.5

MINI MAX





	<p>WARNING</p> <p>USE EXTREME CAUTION WHILE USING THIS EQUIPMENT. INJURY CAN OCCUR. READ CAREFULLY AND UNDERSTAND ALL ASSEMBLY AND SAFE OPERATION INSTRUCTIONS BEFORE OPERATING. FAILURE TO FOLLOW THE SAFETY RULES AND OTHER BASIC SAFETY PRECAUTIONS MAY RESULT IN SERIOUS PERSONAL INJURY.</p>	
---	--	---



Table of Contents

- 1 INTRODUCTION..... 5
 - 1.1... Application..... 5
 - 1.2... Benefits..... 5
 - 1.3... Navigating This Manual..... 5
 - 1.4... Warnings and Safety Precautions 6
 - 1.5... Operation References/Terminology..... 7
 - 1.6... Owner Assistance 8
 - 1.7... Model Identification 8
 - 1.8... Further Assistance..... 8
- 2 SAFETY 9
 - 2.1... General Safety Rules..... 9
 - 2.2... PRODUCT-SPECIFIC SAFETY RULES.....10
 - 2.3... ENGINE SAFETY PRECAUTIONS11
 - 2.4... Safety Decals.....14
 - OIL RECOMMENDATIONS..... 19
 - 4.1... Checking and Adding Oil.....20
 - 4.2... Oil.....20
 - 4.3... Changing Oil.....21
- 5 FUEL 21
 - 5.1... Preparing the Engine for Starting.....21
 - 5.2... Filling the UNIT'S FUEL TANK.....21
- 6 OPERATION..... 22
 - 6.1... Training22
 - 6.2... Preparation.....22
 - 6.3... General Operation23
 - 6.4... Before Operation23
 - 6.5... Initial Operation.....25
 - 6.6... Operating Controls – Speed25



6.7... *Operating Controls – Depth of Tilling*.....25

6.8... *Operating Controls – Throttle Lever*25

6.9... *Tilling Operation*25

6.10. *Tilling Pattern*26

6.11. *Cultivating Operation*26

6.12. *Wheel Height Adjustment*.....26

6.13. *Tine Adjustment*.....26

7

7.7... *Engine Oil*.....29

8 LUBRICATION 30

~~8.1... *Wheels*.....30~~

~~8.2... *Throttle Lever Pivots*.....30~~

8.3... *Starting and Stopping the Engine*30

8.4... *Pre-Start*.....31

8.5... *Cold Engine Starting Instructions*31

8.6... *Warm Engine Starting Instructions*31

8.7... *Hot Engine Starting Instructions*.....31

8.8... *Stopping Engine Instructions*.....32

9 TINE INSTALLATION AND REMOVAL..... 32

9.1... *Installing Tines*.....32

9.2... *Removing Tines*.....32

9.3... *Adjusting Wheels*.....33

9.4... *Adjusting Drag Stake*33

9.5... *Transporting your Unit*.....33

10 STORAGE 33
10.1. Long Term Storage33
10.2. Short Term Storage.....34
11 TROUBLESHOOTING..... 35
12 PARTS BREAKDOWN..... 36
12.1. Handlebar Breakdown36
12.2. Wheels and Tines Parts Breakdown.....37
12.3. Hood and Transmission Assembly Parts Breakdown38
12.4. General Information.....39
13 WARRANTY..... 40
13.1. Warranty/Product Registration40

 **WARNING**

READ ENTIRE MANUAL BEFORE ATTEMPTING TO OPERATE MACHINE

If incorrectly used, this machine can cause severe injury. Those who use and maintain this machine should be trained in its proper use, warned of its dangers, and should read the entire manual before attempting to set up, operate, adjust, or service this machine.

Read and keep this manual for future reference. This manual contains important information on **SAFETY, ASSEMBLY, OPERATION, AND MAINTENANCE**. The owner must be certain that all the product information is included with the unit. This information includes the **MANUAL, the REPLACEMENT PARTS** and the **WARRANTIES**. This information must be included to make sure state laws and other laws are followed. This manual should remain with the product even if it is resold.

 **WARNING**

THE ENGINE EXHAUST FROM THIS PRODUCT CONTAINS CHEMICALS KNOWN TO THE STATE OF CALIFORNIA TO CAUSE CANCER, BIRTH DEFECTS OR OTHER REPRODUCTIVE HARMS.

IMPORTANT: This unit is equipped with an internal combustion engine and should not be used on or near any unimproved forest-covered, brush covered, or grass-covered land unless the engine’s exhaust system is equipped with a spark arrester meeting applicable local laws (if any). If a spark arrester is used, it should be maintained in effective working order by the operator.

In the state of California, a spark arrester is required by law (section 4442 of the California public resources code). Other states may have similar laws. Federal laws apply on federal lands. See your authorized service center for a spark arrester.

1 INTRODUCTION

Maxim's Mini Max Tiller Cultivator features an exclusive, heavy-duty transmission, extra wide tilling width of up to 16", powered by a Honda Engine to keep your tiller running strong for years to come. That's just a few of the benefits of this tiller and we're certain you'll find that it's easy to use, handles smoothly and accurately weeds and tills. It has serpentine tines that till and turn up the soil (up to 8") to create a soft, smooth seed bed even in the most tough ground conditions. Please be sure to read the owner's manual and familiarize yourself with your new tiller and how to care for your unit, so that it will provide you with many years of service. It's this simple, yet sturdy design that makes Maxim tillers low maintenance and easy to use.

Please read this entire manual before assembly and use. The manufacturer reserves the right to change, alter or improve the product and this document at any time without prior notice.

1.1 Application

The Mini Max is versatile to say the least. You can till or cultivate all with one machine. Start by tilling hard soil to create new garden beds or prepare soil for planting by loosening soil. Once planted, you can cultivate your garden to loosen the ground around the plants. Cultivating will improve aeration and the plants ability to absorb water and nutrients. Cultivating also makes easy work out of weeding the garden. By loosening the soil around plants, you are easily able to remove weeds before they establish roots. The MTC35H tiller combine ease of operation and maintenance to make a tiller worthy of the Maxim name.

1.2 Benefits

- Heavy-Duty Transmission – our rugged, exclusive transmission design ensures your tiller will power through tough ground conditions, maintain existing or overgrown gardens with ease.
- 4 Cycle Honda Engine – Powered by a 35cc Honda Engine means No Mix, No Mess, No Fuss! The power and dependability of a Honda Engine ensures your tiller will start, outperform and deliver results.
- 16" Wide Tilling Width – Cut big jobs down to size in a hurry with our wide 16" tilling width. Perfect to fit any garden with tilling widths of 7", 13" or 16".
- Lift Handle/Bumper guard – Makes it easy to move the tiller and protects your engine from accidental damage.
- Steel Forged Tines – 6 Rugged and durable steel forged tines deliver superior tilling and long life.
- Transport Wheels and Drag Stake Standard – Our transport wheels and drag stakes are easily adjustable, with no tools needed.

1.3 Navigating This Manual

1. Use this manual to help familiarize yourself with safety, assembly, operation, adjustments, troubleshooting, maintenance, specifications and warranty information. It is very important that you read this manual and follow the instructions to ensure safe operation of the tiller.
2. Please visit www.maximmfg.com for updated information.

1.4 Warnings and Safety Precautions

The safety of our customers and other’s well-being is very important to us. Using this equipment is an important responsibility. Accurate assembly and safe and effective use of the machine is the owner’s responsibility.

- Read and follow all safety instructions
- Carefully follow all assembly instructions
- Maintain the machine according to directions and schedule included in this manual.
- Ensure that anyone who uses the machine is familiar with all controls and safety precautions.

SPECIAL MESSAGES

Your manual contains special message to bring attention to potential safety concerns, machine damage as well as helpful operating and servicing information. Please read all the information carefully to avoid injury and machine damage. This information alerts you to potential hazards that could hurt you or others.

NOTE: General information is given throughout the manual that may help the operator in the operation or service of the machine.

You will find important safety information in a variety of forms, including:

1. Safety labels – on the tillers
2. Safety messages – preceded by a safety alert symbol  and one of the three signal words: **DANGER, WARNING, OR CAUTION.**

These signal words mean:

DANGER: You will be killed or seriously injured if you don’t follow instructions



WARNING: You can be killed or seriously injured if you don’t follow instructions.

 WARNING
WARNING INDICATED A HAZARD WHICH, IF NOT AVOIDED, COULD RESULT IN DEATH OR SERIOUS INJURY AND/OR PROPERTY DAMAGE

CAUTION: You can be injured if you don’t follow instructions.

 CAUTION
CAUTION INDICATED YOU CAN BE HURT OR YOUR EQUIPMENT DAMAGED IF THE SAFETY INSTUCTIONS THAT FOLLOW THIS SIGNAL WORD ARE NOT OBEYED.

⚠ WARNING**CALIFORNIA PROPOSITION 65 WARNING**

ENGINE EXHAUST FROM THIS PRODUCT CONTAINS CHEMICALS KNOWN TO THE STATE OF CALIFORNIA TO CAUSE CANCER, BIRTH DEFECTS, OR OTHER REPRODUCTIVE HARM.

⚠ WARNING

YOU MUST READ, UNDERSTAND AND COMPLY WITH ALL SAFETY AND OPERATING INSTRUCTIONS IN THIS MANUAL BEFORE ATTEMPTING TO SETUP AND OPERATE YOUR MACHINE.

FAILURE TO COMPLY WITH ALL SAFETY AND OPERATING INSTRUCTIONS CAN RESULT IN LOSS OF MACHINE CONTROL, SERIOUS PERSONAL INJURY TO YOU AND/OR BYSTANDERS, AND RISK OF EQUIPMENT AND PROPERTY DAMAGE. THE TRIANGLE IN THE TEXT SIGNIFIES IMPORATNT CAUTIONS OR WARNINGS WHICH MUST BE FOLLOWED

⚠ This symbol points out important safety instructions which if not followed could endanger your personal safety. Read and follow all instructions in this manual before attempting to operate this equipment.

BEFORE OPERATING ENGINE:

Please read this section carefully. Read entire operating and maintenance instructions for this product. Failure to follow instructions could result in serious injury or death. Operate the machine according to the safety instructions outlined here and inserted throughout the text. Anyone who uses this machine must read the instructions and be familiar with the controls.

Intended Use / Foreseeable Misuse

IMPORTANT: This is a motorized rotary tiller that works the soil by means of rotating tines. It is pedestrian-controlled, but not self-propelled, with a gasoline-fueled internal combustion engine to power the tines. It shall not be used for any other purpose.

1.5 Operation References/Terminology

References throughout this manual referred to as “Right” or “Left” are determined by being positioned behind tiller and facing the direction the unit will operate while in use.

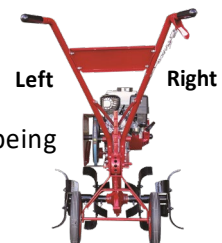

2 SAFETY

2.1 General Safety Rules

- Read, understand and follow all instructions on the machine and in the manual(s). Be thoroughly familiar with the controls and proper use of the machine before starting.
- Use this equipment for its intended purpose only.
- Familiarize yourself with all of the safety and operating decals on this equipment and on any of its attachments or accessories.
- Do not put hands or feet near or under rotating parts.
- Only allow responsible individuals who are familiar with the instructions to operate the machine. Do not allow children to operate this machine. Do not allow adults to operate the machine without proper instruction.
- Thoroughly inspect the area where the machine is to be used and remove all foreign objects. Your equipment can propel small objects at high speed causing personal injury or property damage. Stay away from breakable objects, such as house windows, automobiles, greenhouse, etc.
- Wear appropriate clothing such as sturdy, rough-soled shoes (steel toe recommended) and close fitting pants and shirt. Loose fitting clothes or jewelry can be caught in moving parts. Never wear shorts. Never wear sandals, sneakers or open shoes, and never operate the machine with bare feet.
- Do not wear loose clothing or jewelry. They can get caught in moving parts. Always keep hands, feet, hair and loose clothing away from any moving parts on engine and machine.
- Always wear safety goggles or safety glasses with side shields when operating the machine to protect your eyes from foreign objects which can be thrown from the unit.
- Always wear a protective hearing device.
- Always wear work gloves and sturdy rugged soled footwear. Wear footwear that will improve footing on slippery surfaces. Leather work shoes or short boots work well for most people. These will protect the operator's ankles and shins from small sticks, splinters, and other debris.
- It is advisable to wear protective headgear to prevent the possibility of being struck by small flying particles, or being struck by low hanging branches, twigs or other objects which may be unnoticed by the operator.
- Do not operate the machine without proper guards or other safety protective devices in place.
- See manufacturer's instructions for proper operation and installation of accessories. Only use accessories approved by the manufacturer.
- Operate only in daylight.
- Do not operate product when fatigued or under the influence of alcohol, drugs or other medication which can cause drowsiness or affect your ability to operate machine safely.
- Never operate machine in wet grass. Always be sure of your footing; keep a firm hold on the handle and walk; never run.
- Watch for traffic when operating tiller near, or when crossing roads.
- If the equipment should start to vibrate abnormally, stop the engine (motor), flip the ON/OFF switch to the **OFF** position.

- Regularly inspect the machine. Make sure parts are not bent, damaged or loose.
- Temperature of muffler and nearby areas may exceed 150° F (65° C). Allow muffler and engine areas to cool before touching.
- Never pick up or carry the machine while the engine is running.
- Prolonged exposure to noise and vibration from gasoline engine-powered equipment should be avoided. Take intermittent breaks and/or wear ear protection from engine noise as well as heavy work gloves to reduce vibration in hands.
- Keep all screws, nuts and bolts tight.
- Do not transport the machine from one place to another with the engine running.
- Check local regulations for age restrictions on use of this machine.

2.2 PRODUCT-SPECIFIC SAFETY RULES

- Do not till above underground utilities, including water lines, gas lines, electric cables or pipe. Contact appropriate utility representatives to determine if/where electrical cables, gas lines, water lines, etc. are buried BEFORE operation.
- Do not operate the machine on terrain/soil with large rocks and foreign objects which can damage the equipment. Never work on excessively deep slopes.
- After striking a foreign object, stop the engine. Flip the ON/OFF switch to the **OFF** position. Remove spark plug wire and allow unit to cool before beginning repairs. Inspect the machine for damage. If damaged, repair before starting and operating the machine.
- The tines of the tiller should not rotate when the engine is idling. If they do, contact your local dealer or Maxim technical service for instruction.
- If an object becomes lodged in the tines, flip the ON/OFF switch to the **OFF** position, remove spark plug wire and allow unit to cool before attempting to remove the foreign object.
- This engine produces carbon monoxide (an odorless, deadly gas). **Never run this unit indoors or in an enclosed area.**
- During this break-in period clutch slippage may occur. The clutch should be kept free of oil or other moisture for efficient operation.
- Always make sure the engine is off whenever maintenance, cleaning or transporting is being done on the unit.
- Always inspect the area to be cultivated and make sure it's free of any objects that could be thrown out by the unit. This device should only be operated by suitably trained adult individuals who have read the entire instruction manual.
- Always wear quality safety shoes when operating this unit.

2.3 ENGINE SAFETY PRECAUTIONS

WARNING

ENGINES GIVE OFF CARBON MONOXIDE, AN ODORLESS, COLORLESS, POISONOUS GAS. CARBON MONOXIDE MAY BE PRESENT EVEN IF YOU DO NOT SMELL OR SEE ANY ENGINE EXHAUST. BREATHING CARBON MONOXIDE CAN CAUSE NAUSEA, FAINTING OR DEATH, IN ADDITION TO DROWSINESS, DIZZINESS AND CONFUSION. IF YOU EXPERIENCE ANY OF THESE SYMPTOMS, SEEK FRESH AIR AND MEDICAL ATTENTION IMMEDIATELY.

CAUTION

HOT GASES ARE A NORMAL BY-PRODUCT OF A FUNCTIONING INTERNAL COMBUSTION ENGINE. FOLLOW ALL SAFETY INSTRUCTIONS TO PREVENT BURNS AND FIRES.

DO NOT ALTER/MODIFY ENGINE:

NEVER ALTER OR MODIFY THE ENGINE FROM THE FACTORY. SERIOUS INJURY OR DEATH MAY OCCUR IF ENGINE IS MODIFIED OR ALTERED.

WHEN WORKING ON OR REPLACING PARTS FOR THE ENGINE OR PRODUCT, YOU MUST ALWAYS FLIP THE ON/OFF SWITCH TO THE OFF POSITION.

PREVENTING CARBON MONOXIDE POSIONING

- Always start and run engine outdoors. Do not start or run engine in an enclosed area, even if doors or windows are open.
- Never run engine indoors as carbon monoxide can reach dangerous levels quickly
- Never try to ventilate engine exhaust indoors. Carbon monoxide can reach dangerous levels very quickly.
- Never run engine outdoors where exhaust fumes may be pulled into a building.
- Never run engine outdoors in a poorly ventilated area where the exhaust fumes may be trapped and not easily taken away. (Examples include: in a large hole or areas where hills surround your working area.)
- Never run engine in an enclosed or partially enclosed area. (Examples include: buildings that are enclosed on one or more sides, under tents, car ports or basements.)
- Always run the engine with the exhaust pointed in the direction away from the operator.
- Never point the exhaust towards anyone. People should always be a minimum of ten feet away from the operation of the engine and its attachments.
- Do not change the engine governor settings or over-speed the engine.

GASOLINE FIRES AND HANDLING FUEL SAFELY

⚠ Warning gasoline is highly flammable and explosive

You can be burned or seriously injured when handling fuel. Use extreme care when handling gasoline or other fuels. They are flammable and vapors are explosive.

- When storing extra fuel be sure that it is in an appropriate container and away from any fire hazards.
- Prevent fire and explosion caused by static electric discharge. Use only nonmetal, portable fuel containers approved by the Underwriter's Laboratory (U.L.) or the American Society for Testing & Materials (ASTM).
- Always fill fuel tank outside in a well-ventilated area. Never fill fuel tank with fuel indoors. (Examples include: basement, garage, barn, shed, house, porch, etc.) Never fill tank near appliances with pilot lights, heaters, or other ignition sources. If the fuel has to be drained, this should be done outdoors. The drained fuel should be stored in a container specifically designed for fuel storage or it should be disposed of carefully.
- Never remove the fuel cap or add fuel with the engine running. Stop engine and allow to cool before filling.
- Do not smoke while using engine or around fuel.
- Never drain fuel from engine in an enclosed area.
- Always wipe up excess (spilled) fuel from engine before starting. Clean up spilled fuel immediately. If fuel is spilled, do not start the engine but move product and fuel container from area. Clean up spilled fuel and allow to evaporate and dry after wiping and before starting.
- Allow fuel fumes/vapors to escape from the air before starting the engine.
- Test the fuel cap for proper installation before starting and using engine. Never start without fuel cap.
- Always run the engine with fuel cap properly installed on the engine.
- Never smoke while refilling engine fuel tank.
- Do not store engine with fuel in fuel tank indoors. Fuel and fuel vapors are highly explosive.
- Never pour fuel from engine fuel tank.
- Never siphon fuel by mouth to drain fuel tank.
- Always have an adult fill the fuel tank and never allow children to fill the engine.
- Never allow anyone under the influence of drugs or alcohol to fill the engine.
- When storing gasoline or equipment with fuel in the tank, store away from furnaces, stoves, water heaters or other appliances that have a pilot light or other ignition source because they can ignite gasoline vapors.

**BURNS AND FIRES**

The muffler, muffler guard and other parts of the engine become extremely hot during the operation of the engine. These parts remain extremely hot after the engine has stopped.

- Never remove the muffler guard from the engine.
- Never touch the muffler guard because it is extremely hot and will cause severe burns.
- Never touch parts of the engine that become hot after operation.
- Always keep materials and debris away from the muffler guard and other hot parts of the engine to avoid fires.

CHILDREN AND BYSTANDERS

Tragic accidents can occur if the operator is not alert to the presence of children and/or bystanders. Never assume that others will remain where you last saw them.

- Keep the area of operation clear of all persons, especially small children and pets. Keep children under the watchful care of a responsible adult.
- Be alert and turn machine off if children enter the area.
- Before and while moving backwards, look behind and down for small children.
- Never allow children to operate the machine.
- Use extra care when approaching blind corners, shrubs, trees, or other objects that may obscure vision.

SERVICE

- Always stop the engine whenever you leave the equipment, before cleaning, repairing or inspecting the unit. Engine should be turned off and cool. Never make adjustments or repairs with the engine (motor) running. Flip the ON/OFF switch to the **OFF** position to prevent accidental starting.
- Always wear eye protection when you make adjustments or repairs.
- Keep all nuts and bolts tight and keep equipment in good condition.
- Never tamper with safety devices. Check their proper operation regularly.
- When servicing or repairing the machine, do not tip the machine over or up unless specifically instructed to do so in this manual. Service and repair procedures can be done with the machine in an upright position. Some procedures will be easier if the machine is lifted on a raised platform or working surface.
- To reduce fire hazard, keep machine free of grass, leaves or other debris build-up. Clean up oil or fuel spillage. Allow machine to cool before storing.
- Stop and inspect the equipment if you strike an object. Repair, if necessary, before restarting.
- Clean and replace safety and instruction decals as necessary.
- To guard against engine over-heating, always have engine air filter mounted and clean.
- Inspect machine before storage. When not in use, flip the ignition ON/OFF switch to the **OFF** position and store indoors in a dry place locked or otherwise inaccessible to children.
- Use only original equipment parts from the factory, including all nuts and bolts.

2.4 Safety Decals

This Tiller has been designed and manufactured to provide you the safety and reliability you would expect from an industry leader in outdoor power equipment manufacturing.

Reading this manual and the safety instructions it contains will provide you with the necessary basic knowledge to operate this equipment safely and effectively. We have placed safety decals on the tiller to remind you of some of this important information while you are operating the unit.

These important safety decals are illustrated below and are shown here to help familiarize you with the content of the safety messages you will see as you perform normal tilling operations. Please review these decals now, and if you have any questions regarding its meaning or how to comply with these instructions, reread the complete safety instruction text in this manual, or contact your local dealer.

Should a decal become unreadable because of being worn, faded or otherwise damaged during the use of your tiller; please use the part number information provided to order a replacement label. These decals are easily applied and will act as a constant visual reminder to you, and others who may use the equipment, to follow the safety instructions necessary for safe, effective operation of your tiller.

<p>Item # 366720</p> 	<p>Item # 336784</p> 	<p>*Special Order</p> 	<p>Item # ZS001</p> 
<p>Item # 799546</p>			
<p>Item # 336799</p> 	<p>*Special Order</p> 		

⚠ CAUTION

4.1 Checking and Adding Oil

1. Never fill the oil with the machine laying on its side. Only add oil when the machine is laying forward on the bumper guard as shown in Figure 3 on page 21. Be sure the engine is located on a level surface before checking or refilling oil. Clean around oil fill area.
2. Be sure engine is cool.
3. Unscrew dipstick and wipe clean with cloth.
4. Reinsert dipstick (do NOT thread for accurate reading)
5. Remove and check dipstick. If no oil shows on the dipstick, refill so that the oil level appears between the low and high marks on the dipstick.
6. Never add more oil than the maximum capacity

***NOTE: See engine Owner's Manual for proper oil maintenance instructions**

⚠ IMPORTANT

ENGINE MUST BE ON LEVEL SURFACE WHEN CHECKING OIL LEVEL OR FILLING WITH OIL. FAILURE TO DO SO CAN RESULT IN OVERFILLING THE ENGINE WITH OIL WHICH WILL IMPAIR THE ENGINE'S PERFORMANCE.

4.2 Oil

- Oil is a major factor that affects the performance and can help extend the life of the cultivator.
- Use quality automotive detergent oil.
- Non-detergent oil and 2-stroke can shorten the engine's service life as well as cause damage to the engine.
- SAE 10w30 is recommended for general use.
- Chart A shows the recommended temperature range – See Engine Owner's Manual. After every 10 hours of accumulated run time, you need to check the oil level in the crankcase and add as needed per the instructions in Figure 3 and 4 (below).

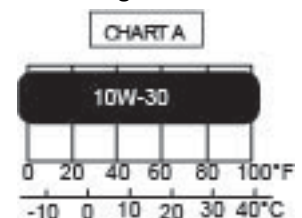
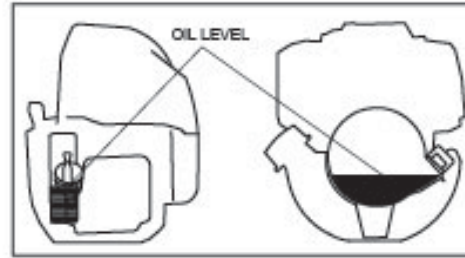



Figure 3



Figure 4



- To check or add oil, place machine on level surface. Tip the machine forward as shown in Figure 3.
- Remove the oil filler cap/dipstick, wipe clean and reinsert without screwing in. Check the level then add recommended oil. Fill to the edge of the oil filler hole.
- Screw cap in securely. **DO NOT OVERFILL WITH OIL!** The crankcase capacity is 3.4 ounces

5 FUEL

5.1 Preparing the Engine for Starting

SEE YOUR ENGINE OWNER'S MANUAL FOR DETAILS SPECIFIC TO YOUR ENIGNE. Unleaded gas, with 86 Octane or higher is required. Fresh fuel will help to insure a longer service life for your machine. Please use fresh fuel, purchased within 30 days from the date of use. **DO NOT MIX OIL WITH GASOLINE.**

CAUTION

Never run with E85 gasoline. Severe engine damage will occur

5.2 Filling the UNIT'S FUEL TANK

SEE YOUR ENGINE OWNER'S MANUAL FOR DETAILS SPECIFIC TO YOUR ENIGNE.

We recommend the use of clean, fresh, lead-free gasoline. The use of lead-free gasoline results in few combustion deposits and longer valve lift. Do not fill the fuel tank completely, allow space for fuel to expand. Provide approximately $\frac{1}{4}$ " of tank space for fuel expansion.

- If the engine has been running, shut it off and allow the engine to cool completely.
- Move the unit to a well-ventilated area away from any open flames or sparks.
- Make sure the area around the fuel cap is clean and clear of debris.
- Loosen fuel cap slowly. Prevent the cap from coming in contact with dirt or debris.
- Carefully fill the gas tank taking care not to spill.
- Do not fill the tank completely. Allow space for air to expand.
- Immediately replace the fuel cap and secure it tightly.
- Clean any spillage around the cap and the tank and allow area to dry before starting engine.

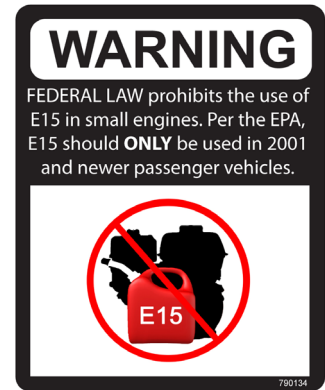

IMPORTANT

- **Fuel and fuel vapors are hazardous and highly flammable. For safety reasons, never store the unit indoors with fuel still in the tank.**
- **Use only containers that are approved by the Underwriters Laboratory (UL) or the American Society for Testing and Materials (ASTM)**

6 OPERATION

6.1 Training

3. Read the Owner's Manual carefully. Be thoroughly familiar with the controls and the proper use of the equipment. Know how to stop the unit and disengage the tines quickly.
4. Never allow children to operate the equipment. Never allow adults to operate the equipment without proper instructions.
5. Keep the area of operation clear of all persons, particularly small children and pets.
6. Always stay alert. Watch what you are doing and use common sense. Do not operate unit when fatigued.
7. Understand the use of all tiller controls.

6.2 Preparation

1. Thoroughly inspect area where the tiller is to be used and remove all foreign objects.
2. Always wear substantial footwear and long pants. Do not operate the equipment when barefoot or wearing open sandals.
3. Wear ear and eye protection. Eye protection must meet applicable CE requirements. To avoid hearing damage, we recommend hearing protection be worn whenever using tiller.
4. Handle fuel with care; it is highly flammable.
5. Use an approved fuel container.
6. Never add fuel to a running engine or hot engine.

7. Fill fuel tank outdoors with extreme care. Never fill fuel tank indoors.
8. Replace gasoline cap securely and clean up spilled fuel before starting.
9. Never attempt to make any adjustments while the engine (motor) is running.

6.3 General Operation

1. Do not put hands or feet near or under rotating parts.
2. Exercise extreme caution when operating on or crossing gravel drives, walks, or roads. Stay alert for hidden hazards or traffic. Do not carry passengers.
3. After striking a foreign object, stop the engine (motor) by turning the ON/OFF switch to **OFF**, thoroughly inspect the tiller for any damage, and repair the damage before restarting and operating the tiller.
4. Exercise caution to avoid slipping or falling.
5. If the unit should start to vibrate abnormally or make unusual noise, stop the engine (motor) and check immediately for the cause. Vibration is generally a warning of trouble.
6. Stop the engine (motor) when leaving the operating position.
7. Take all possible precautions when leaving the machine unattended. Stop the engine by turning the ON/OFF switch to **OFF**.
8. Before cleaning, repairing, or inspecting, shut off the engine and make certain all moving parts have stopped. Disconnect the spark plug wire, and keep the wire away from the plug to prevent accidental starting.
9. Do not run the engine indoors; exhaust fumes are dangerous.
10. Never operate tiller without proper guards, tines or other safety protective devices in place.
11. Keep children and pets away when operating.
12. Do not overload the machine capacity by attempting to till too deep or too fast.
13. Never operate the machine at high speeds on slippery surfaces. Look behind and use care when backing up.
14. Never allow bystanders near the unit.
15. Use only attachments and accessories approved by the manufacturer of the tiller.
16. Never operate the tiller without good visibility or light.
17. Be careful when tilling in hard ground. The tines may catch in the ground and propel the tiller forward. If this occurs, let go of the handlebars and do not restrain the machine.

6.4 Before Operation

1. Check your tiller. Be sure all bolts are tight. After several hours of operating and at periodic maintenance intervals, check all fasteners and tighten securely as required.
2. Check oil and fill according to the engine owner's manual.

 DANGER

To prevent personal injury, the clutch must disengage immediately when throttle lever is released. If it does not, stop the tiller, adjust throttle cable as described in Section 3.2 (Install Throttle Cable) of this manual. Never leave the tiller unattended with the engine running. Children are attracted to a running tiller and could be injured if struck by the rotating tines.

 WARNING

Keep hands clear of tines while engine is running. Never attempt to adjust or clean tines while engine is running, at risk of sever injury.

6.5 Initial Operation

- The clutch will transfer maximum power to the unit's tines for normal operation. During this break-in period, clutch slippage may occur. The unit's clutch should be kept free of all oil and other moisture to ensure efficient operation.
- While cultivating, do not place excessive body weight on the unit. The unit will operate most efficiently with the use of its own weight.

6.6 Operating Controls – Speed

1. The tiller will dig deeper and move forward slower by pushing down on the handles.
2. The tiller will go ahead faster but at a shallower depth by raising the handles
3. The speed of the tines is controlled by the use of the throttle control lever to speed up and slow down.

6.7 Operating Controls – Depth of Tilling

1. The proper throttle speed and correct up and down hand pressure on the handles must be used.
2. Raising up means going forward, this action releases the grip of the drag stake in the soil, allowing the tiller to progress ahead.
3. Pushing down means slowing down or even standing still. This directs the drag stake into the soil, thus holding the tiller back.
4. Adjust throttle for desired speed and depth of tines.

6.8 Operating Controls – Throttle Lever

1. To engage throttle, depress lever to handle.
2. The clutch is disengaged when the throttle lever is away from handle grip.

6.9 Tilling Operation

1. When ground is hard (especially during spring and fall) place wheels in up position by pulling the from the wheel yoke and reposition the wheel frame bar. Adjust locking pin to desired height. Or,

you can remove the wheels during use. For weeding or cultivation, wheels may be left down if you prefer. For best results, operate at reduced throttle settings when ground is extremely hard or rough.

2. Adjust the drag stake for comfortable operation or desired depth. This is done by pulling the detent pin from the drop stake locking hub and sliding the drag stake down or up. The drag stake should be set so that when it is firmly in the ground, and your hands are on the tiller handle, your arms hang comfortably with the elbows light bent.
3. Tighten all nuts and bolts periodically.
4. Start the engine by following the engine starting procedure in section 9.2-9.6 and allow it to warm up.
5. To begin tilling, squeeze the throttle lever located on the handlebar tightly to engage tines.
6. When you find the right amount of downward pressure so that the tines are digging and the tiller is moving forward, release the pressure slightly.
7. Don't hurry the job – proceed at a slow walk – give the machine time to do its job.

⚠ NOTE: The whole tilling operation is controlled by the amount of pressure you put on the drag stake. Do not fight the tiller. Stand between the handles and press down to go slower and dig deeper and release the downward pressure to move forward faster. In normal soil, the actual up and down movement of the handles will be no more than an inch or two.

6.10 Tilling Pattern

1. Whenever possible till the soil in the direction in which the planting or rows will run. If the soil is extremely hard and dry, it may be advisable to till across the plot on the first digging and then obtain the depth you want by tilling in the direction the planting will be done.

6.11 Cultivating Operation

1. Remove drag stake.
2. Be cautious as the tiller can pulled faster and harder without drag stake.
3. Ensure your feet are planted firmly on ground and you have a solid grip on tiller.

6.12 Wheel Height Adjustment

1. Wheel position may be adjusted. To place wheels in up position, pull the locking pin from the wheel yoke and reposition the wheel frame bar and lock wheels in the up position. For weeding or cultivation, wheels may be left down if you prefer.

6.13 Tine Adjustment

The standard tilling width is 16" with both inner and outer tine assemblies mounted. Tilling width is 7" with outer assemblies removed.

1. To remove outer tine assemblies from inner tine assemblies, remove pin clip from clevis pin.
2. Slide clevis pin out and remove outer tine assembly.

4. Service the air filter every 25 hours of operation. Clean the air filter daily when used in dry, dusty or other extreme conditions. If dust is visible in the air while the machine is in operation, the air filter should be cleaned.

7.3 Foam Element Air Cleaner

Check and Clean Before each use

REFER TO YOUR ENGINE'S OWNER'S MANUAL FOR SPECIFIC INFORMATION RELATING TO YOUR ENGINE.

 NOTE: Service more often under dust conditions.

1. Remove the air cleaner cover and remove cover.
2. Remove the foam filter.
3. Wash in warm water with liquid detergent until dirt and debris is removed. Press or squeeze the filter when cleaning...**DO NOT TWIST!**
4. Dry the filter by wrapping it in a dry cloth and pressing it until the water is removed.
5. Apply lightweight motor oil or thin based machine oil to the entire filter. Remove excess oil.
6. Re-attached the filter and cover to the unit.
7. Inspect air filter and replace if damaged.
8. Always replace the foam air filter element per service guidelines in the engine manual.

Never tamper with the factory setting of the carburetor! Carburetors are set by the factory in accordance with federal law. There are no user serviceable parts or adjustments.

7.6 Periodic Check

1. Regularly check all bolts and nuts for tightness.

7.7 Engine Oil

1. Check the oil level before starting the engine and after every five hours of operation.
2. Be sure engine is cool.
3. Before removing the filler plug, clean the area around it to prevent dirt from entering the oil fill hole.
4. The engine should be in a level position when checking the oil.
5. Remove the filler plug and fill the crankcase with oil.
6. Use a high-quality detergent oil – refer to your engine owner’s manual for oil requirements.
7. Add oil as necessary to keep oil level as indicated. Detergent oils keep the engine cleaner and reduce the formation of gum and varnish deposits. Nothing should be added to the recommended oil.
8. Change the oil after the first 20 hours of operation and every 100 hours there-after or every 6 months, whichever comes first. Always change oil while the engine is warm. Oil may be drained through the oil drain port towards the bottom of the engine. Refer to your Engine Owner’s Manual for complete details.

7.9 Cleaning

⚠ IMPORTANT: If the engine has been running, allow it to cool for at least half an hour before washing.

1. Wash the tiller, including the underside, after use.
2. Wash the engine by hand and be careful to prevent water or debris from entering the air cleaner.

⚠ NOTE: Do not use a garden hose or pressure washing equipment, it can force water into the air cleaner. Water in the air cleaner will soak the filter element and can enter the carburetor or engine cylinder, causing damage.

3. After washing the tiller, wipe dry.
4. After the tiller is clean and dry, touch up any damaged paint and coat other areas with a light film of oil.
5. Wipe the tines with oil or spay to prevent rusting.

8 LUBRICATION

8.1 Wheels

Lubricate wheels and wheel support shafts once a month or every 40 operation hours with #30 oil or penetrating lube. Apply oil/lube to axle and hub at back of wheel. Spin to allow oil/lube to move into wheel and bolt.

In extremely dusty conditions, wheels may become tight because of dust in bearing area. When this condition occurs, remove the wheels. Clean axle and wheel surfaces with solvent or emery cloth, then oil and reassemble.

8.2 Throttle Lever Pivots

Apply a Few drops of SAE 30 oil to the throttle lever as required to maintain a free and smooth operation of clutch.

8.3 Starting and Stopping the Engine

Before starting the engine, check the machine against the Set-Up instructions to see that it is properly assembled. Review the safety suggestion and operating instructions for safe and proper use of the tiller.

1. To prevent carbon monoxide poisoning (also see engine safety precautions) always move the unit outdoors to a well-ventilated area before starting.
2. Always be aware of gas vapors and exhaust fumes. Before starting the engine, make sure it is away from open flames or sparks.
3. Make sure the air filter holes and the fuel tank area are free of debris.

WARNING

Always make sure the unit is in a stable position before pulling the starter handle. Once the unit starts to engage, momentarily release the throttle control with your right hand. Move both hands to the handlebar position and use the handlebar to maintain control and stability of the unit.

WARNING

When starting the unit, the starter rope can sometimes cause an unanticipated jerk back towards the engine. Follow the instructions carefully to avoid any injuries. Always turn off the engine after every use. Never leave it running unattended.

Never carry or move from the location while the engine is running. Always follow the gas and oil instructions. Wear approved hearing protection. Do not attempt to start when there is fuel spillage present. Always clean up any spillage.

8.4 Pre-Start

1. Check the spark plug wire for proper connection to the spark plug.
2. Fill the fuel tank with clean, fresh, regular gasoline from a sealed container.
3. Check the oil for proper level.
4. Make certain throttle cable is in disengaged position.

8.5 Cold Engine Starting Instructions

Starting the engine for the first time or after running out of fuel or if the engine has cooled off:

1. Move choke lever to the CLOSE position.
2. Use the primer bulb to prime the unit until the primer hose and bulb are full of gas.
 - a. **NOTE:** When using the primer bulb, allow the primer bulb to completely return to its original position after each pump
3. Push the rocker switch to the ON position.
4. Grasp the starter rope with your left hand and pull out slowly until the tension becomes slightly harder. Without letting the rope retract, pull the starter rope with a rapid, forearm stroke. Allow the rope to return to its original position. Repeat this step until the engine starts and allow the rope to return to its original position.
 - a. **NOTE:** If the engine fails to start after 5 to 6 pulls, stop pulling, press the primer bulb 1 time and repeat the process.
5. Once the engine has started and has stayed running, move the choke lever to the HALF-CHOKE position until the engine runs smoothly.
 - a. **NOTE:** HALF-CHOKE position is defined as being half-way between CLOSED and OPEN.
6. Once the engine is running smoothly, move the lever to the RUN position.
7. To STOP the engine, move the rocker switch to the OFF position.

8.6 Warm Engine Starting Instructions

1. Move the choke lever to the OPEN position.
 - a. **NOTE:** In the OPEN position, always move the lever to the farthest OPEN position possible.
2. Begin with Step 7 of Cold Engine Starting Instructions.

8.7 Hot Engine Starting Instructions

1. Begin with Step 7 of Cold Engine Starting Instructions.
2. If the engine has not started, refer to Step 1 of Warm Engine Starting Instructions.

DO NOT ATTEMPT TO START THE ENGINE THE FOLLOWING WAYS:

- **DO NOT** use starting fluid
- **DO NOT** spray flammable liquids into the air cleaner, carburetor or spark plug chamber.
- **DO NOT** remove spark plug and attempt to start the engine. Flammable fuel can spray out and ignite from a spark.

8.8 Stopping Engine Instructions

1. Release throttle control to the idle position.
2. Turn ON/OFF switch to OFF position
3. Disconnect the wire from the spark plug to prevent accidental starting of the machine will it is unattended.

9 TINE INSTALLATION AND REMOVAL

9.1 Installing Tines

1. First slide the inside tines onto both ends of the tine shaft. The inside tines are stamped with either the letter "B" or "C".
2. Slide the outside tines onto the tines shaft. The outside tines are stamped with either the letter "A" or "D".
3. The tines should be installed so that they are aligned in a sequence of "A, B, C, D" and should be positioned in that order from left to right when viewed from the user's position of the mini cultivator.
4. Reinsert the cotter pins back on each side of the tine shaft to lock the tines into place.

9.2 Removing Tines

1. Remove the cotter pins from each side of the tine shaft.
2. Slide tines off the shaft.

SEE TINE SETUP OPTIONS ON NEXT PAGE

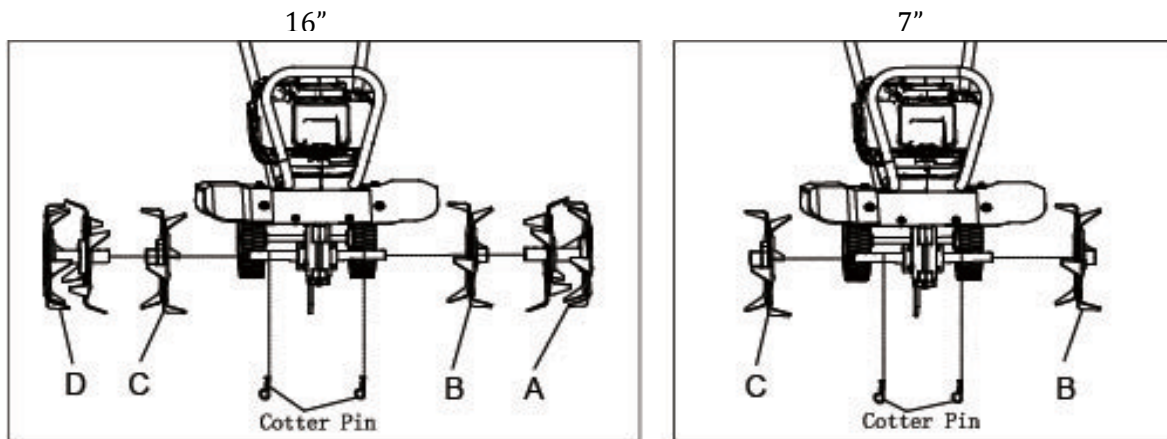
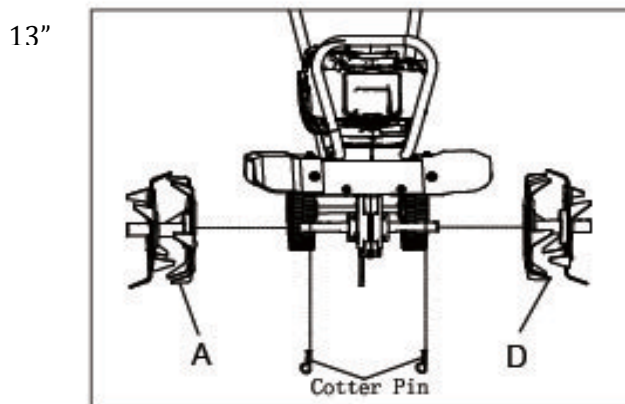

FIGURE 3



9.3 Adjusting Wheels

The wheels on the mini cultivator can be adjusted into three height positions. See Figure 4.

1. To adjust the wheels, pull the locking pin out of the rear wheels mount hold.
2. Put the rear mounted wheels into desired hole height then replace the locking pin.

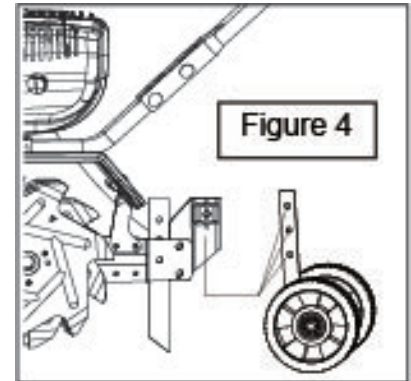

9.4 Adjusting Drag Stake

The drag stake on the mini cultivator can be adjusted easily.

1. The drag stake helps the resistance of forward motion of the tiller, this allows the tiller to dig deeper into soil.
2. The lower the drag stake is set the lower it will work in the soil. In compact or harder soil the drag stake should be set lower. In soft soil, set the drag stake higher. You may prefer to remove the drag stake in soft soil or when cultivating as it may not be necessary for the soil condition.
3. To adjust pull out detent pin, adjust to desired height and reinsert detent pin.

9.5 Transporting your Unit

- After using your mini cultivator, always allow the unit to cool off before transporting. Never transport the unit in an enclosed space within a vehicle as fumes and vapors maybe build up. They could ignite and cause serious injury or even death.
- If fuel is present in the fuel tank, always transport in an open vehicle and in an upright position.
- If an enclosed vehicle must be used, be sure that the fuel tank is empty and any unused gas is secured in a UL or ASTM approved container.
- Never siphon out gas by mouth.
- **Run engine to use up any small amount of remaining fuel left in carburetor and fuel tank.**
- Always run the engine in a well-ventilated area.
- Clean up any spillage around the fuel tank and allow to dry and evaporate.
- Make sure the unit's gas cap is secured tightly before transporting.

10 STORAGE

10.1 Long Term Storage

If you will not be using your mini cultivator for more than 30 days, you need to prepare it for long term storage. Please see your Engine Owner's Manual for storage information relating to engine.

1. Make sure all the fuel is removed from the gas tank.



3. Run the engine to ensure any remaining fuel in the carburetor and tank are used up. The engine should be completely drained of fuel to prevent deposits from forming on essential carburetor parts, fuel filter, fuel lines and tank. Remove spark plug wire.
4. Before storing, wash down the unit to remove all dirt and debris from the body of the unit.
5. Store the cultivator in a stable position.

10.2 Short Term Storage

If you will be using your mini cultivator within 30 days, you need to prepare it for short term storage.

1. If used within 30 days, no fuel stabilizer is needed.
2. Remove spark plug wire, clean unit and inspect for any repairs or service needed.



12.4 General Information

Engine	Honda GX35, 35.8cc
Transmission	Gear Drive
Fuel Tank Capacity	0.67 U.S. qt (.63 liter)
Oil Type	10w30
Oil Capacity	3.4 Ounces (100cc)
Gas Type	See Engine Owner’s Manual Unleaded 86 octane or higher. Never use fuel with more than 10% ethanol. Never use E85 Fuel
Spark Plug	See Engine Owner’s Manual
Spark Plug Gap	See Engine Owner’s Manual
Gear Ratio	32:1
Tine speed (max)	250 RPM
Tines	Steel Forged Tines (6)
Tilling width	7", 13" or 16"
Tilling depth	Up to 8"
Drag Stake	Standard
Handles	3/4" - .06" Thick Q195 Steel
Wheels	1.375 x 7.0" Diameter
Vibration	(Left Handle: 3.34 m’s2) (Right Handle: 3.47 m’s2) k-1.5 m’s2
LpA At Operator’s Position	82.4dB (A) Kpa – 2.5dB (A)
LwA KwA	93 dB (A) 2.5dB (A)
Dimensions (L x W x H)	47" x 17.25" x 36.75"
Shipping weight	50 lbs.



MTC35H



Maxim

20195 S. Diamond Lake Rd, STE 100

Rogers, MN 5537

800-621-2789